



FOR  
SALE

Retail Storefront + Apartment

805 St Clair Avenue W

Retail Storefront located in St Clair West Village

**Lennard:**

200-55 University Avenue, Toronto  
416.649.5920

[lennard.com](http://lennard.com)

# 805 St Clair Avenue W

A retail storefront with residential apartment above



## 805 St Clair Avenue W

PIN	212620143
Legal Description	PT LT 6 PL 1346 TORONTO AS IN CA649289 S/T & T/W CA649289 ; CITY OF TORONTO
ARN	190405361002400



Building Size

**1,791 SF**  
+ Basement



Lot Frontage

**16.92 FT**

Lot Depth

**132.19 FT**



Price

**\$1,895,000**

2024 Final Realty Taxes

**\$14,128.37**

## Property Highlights

- Leaseback of commercial preferred, but vacant possession possible
- Main Floor: fully renovated sales office (Owner occupied)
- 2nd Floor: a vacant 2-bedroom apartment
- Basement: finished and useable basement
- Parking: 2 surface spaces in rear

For more information:



Listing Agents

**Noah Schwartz\***

Senior Vice President • Sale Representative

416.649.5943 • [noah@lennard.com](mailto:noah@lennard.com)

**Lennard:**

# 805 St Clair Avenue W

## Floor Plans

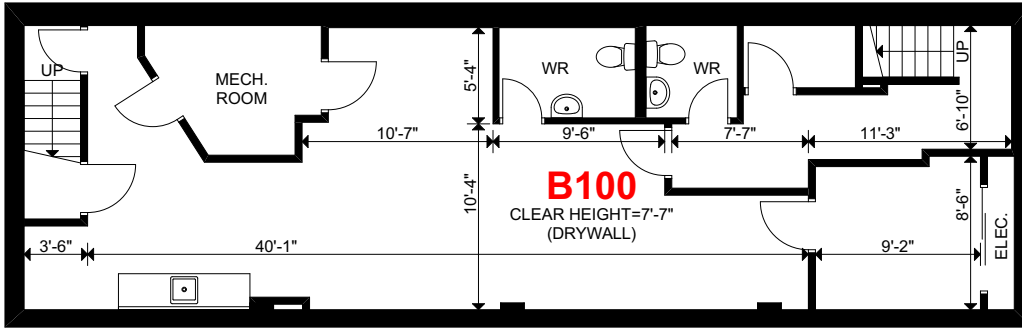

Basement  
964 SF

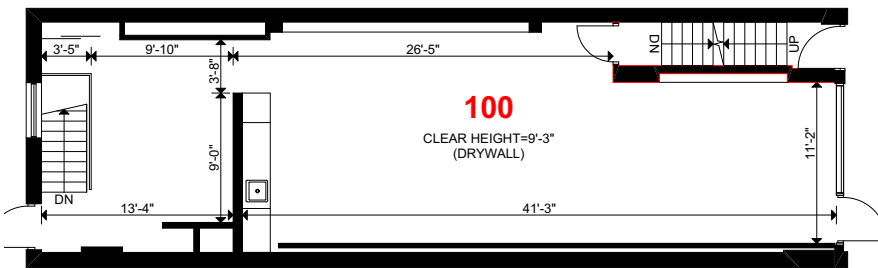

Floor 1  
935 SF

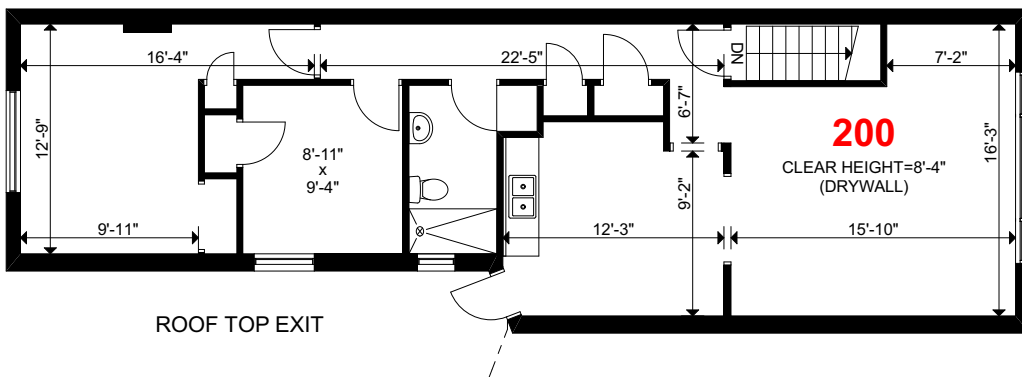

Floor 2  
856 SF



# 805 St Clair Avenue W

## Amenities



### Legend

 805 St. Clair Avenue W

 Public Green Space

 TTC Bus Line

 TTC Streetcar Line

**Lennard:**

# 805 St Clair Avenue W

## In the Area



## Area Demographics

### 1 km Radius

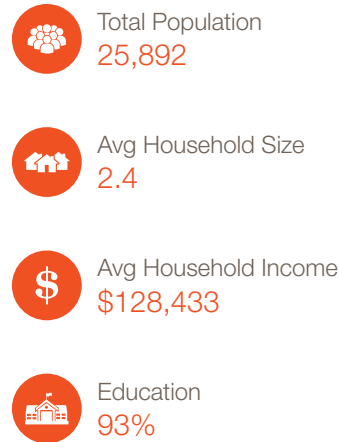

### 3 km Radius

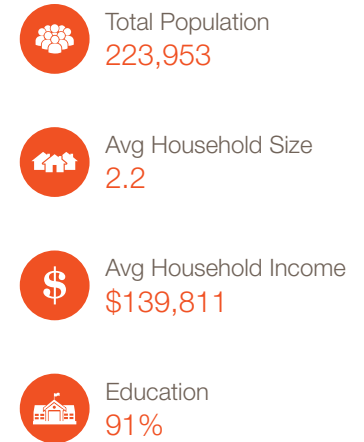

Source: Piinpoint

## Roast Fine Foods

Located just minutes away from 1018 St. Clair Avenue W, Roast Fine Foods provides naturally-raised, antibiotic & hormone-free products that are carefully selected to serve the everyday cook, the gourmand, and busy families who takes special care in the quality of the food they serve.



## Krave Coffee

Located at 781 St Clair Ave W #2, Krave Coffee is a local favorite for a cool, snug spot with a patio offering espresso drinks, clever sandwiches & locally baked goods.



**Lennard:**

# 805 St Clair Avenue W

## Nearby Condo Developments

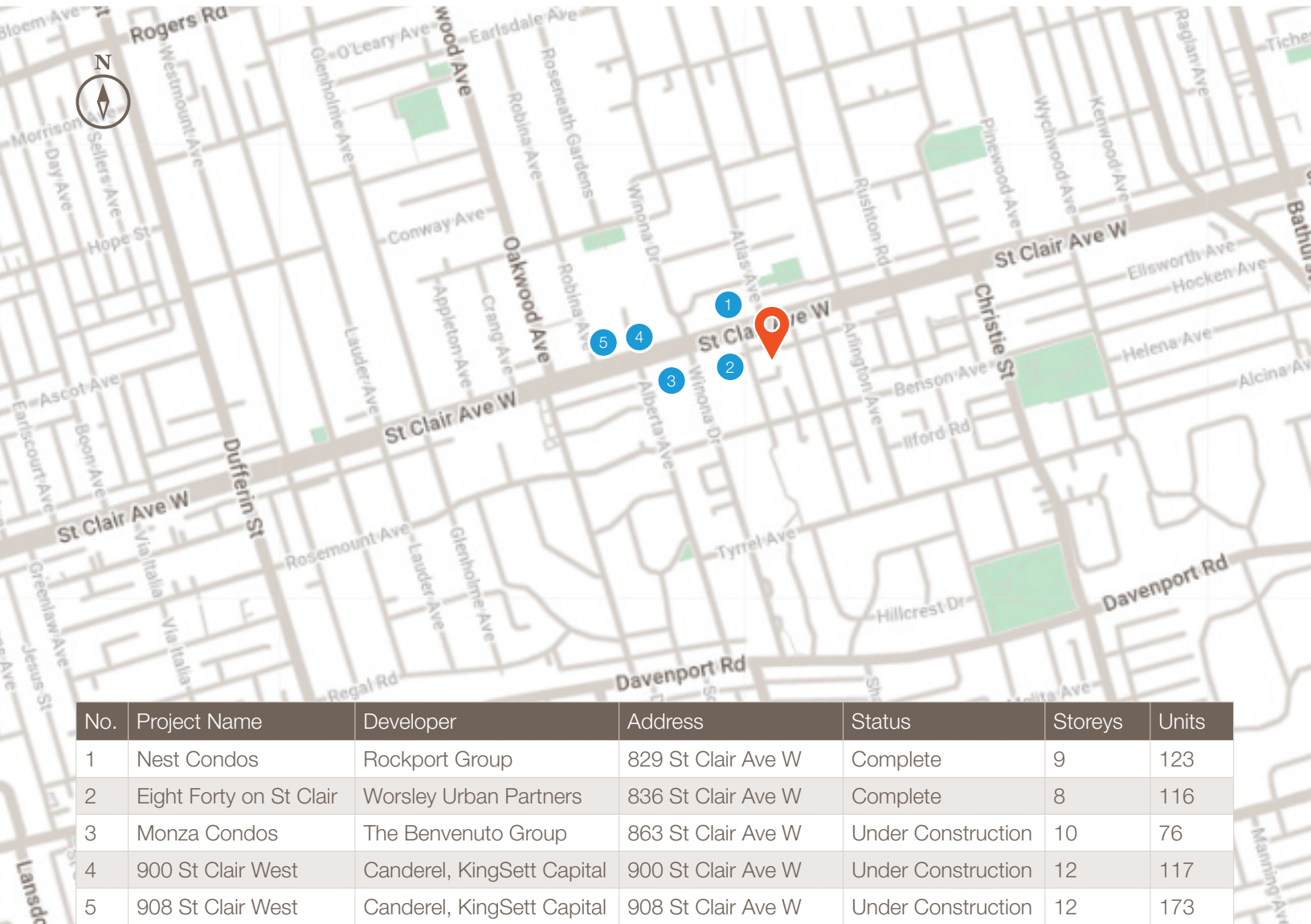

### Legend



805 St. Clair Avenue W

# 805 St Clair Avenue W

Photos



**Lennard:**

# Lennard:

**Noah Schwartz\***

Senior Vice President

416.649.5943

[noah@lennard.com](mailto:noah@lennard.com)

200-55 University Avenue, Toronto

416.649.5920

[lennard.com](http://lennard.com)

\*Sales Representative

Statements and information contained are based on the information furnished by principals and sources which we deem reliable but for which we can assume no responsibility. Lennard Commercial Realty, Brokerage